

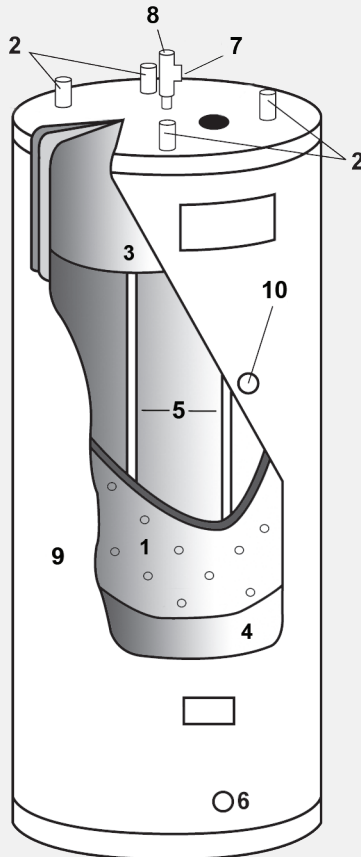

Therma-Stor II-2 HF

TS-224B
Revised 6/11

Heat Recovery Water Heater Specification Information



Therma-Stor plate design, with rapid, free-flowing paths for refrigerant gas, promotes excellent waste heat transfer throughout the tank.

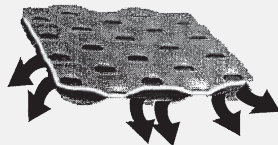

Construction Specifications

1. Dual circuit refrigerant heat exchange plate designed for maximum heat transfer with minimum pressure drop.
2. 1-5/8" O.D. refrigerant inlets and outlets.
3. Industrial glass lined 114-gallon hot water storage tank.
4. 2" foam-in-place urethane insulation (R-16).
5. Dual anode protection against corrosion for extended tank life.
6. 1-1/4" male NPT water inlet.
7. 1-1/4" male NPT water outlet.
8. 150 psi and 195°F pressure/temperature relief valve.
9. Attractive enameled galvanized external wrapper.
10. Mid-tank 3/4" Male NPT connection for recirculating loop return or for aquastat (mid-port).

Overview

The Therma-Stor II-2 High Flow (HF) Heat Recovery Water Heater features a high flow, dual-circuit heat exchanger encompassing a 114-gallon water tank. Each circuit is compatible with refrigeration loads of up to 27 tons (refer to chart on the back). Larger refrigeration loads can be accommodated by piping the circuits together or considering the Therma-Stor II-1 unit.

Operation

The Therma-Stor II-2 HF heats water by transferring refrigerant superheat to water. Hot gas leaving the compressor(s) is piped through the refrigeration circuits en route to the condenser(s). The II-2 HF is compatible with any typical refrigeration system within sizing guidelines (using capillary tube systems with the Therma-Stor is normally not recommended). Plumbing recirculating loop return water to the mid-port allows recirc line losses to be heated with reclaimed heat without affecting overall heating efficiency. Hot water production depends on the evaporator load (capacity), run time of the compressor and water usage (see the Therma-Stor Return On Investment Calculation Form available at www.HeatWaterForFree.com for more information).

Typical Applications

The Therma-Stor II-2 HF is ideally suited for heating water in facilities with larger capacity one or two compressor refrigeration systems.

Common installations include:

- Grocery stores
- Breweries
- Health care facilities
- Walk-in coolers/freezers

Unit Specifications

- Tank Dimensions
Diameter: 29 1/4", Height: 62 1/4"
- Unit Dimensions (with fittings)
Diameter: 31 1/2", Height: 67", Weight: 420 lbs
- 120 gallon nominal water capacity
- Max heat exchange rating 80,000 BTU/hr
- 150 PSI max operating water pressure
- Rated for 450 psi refrigerant operating water pressure
- R-16 insulation
- High refrigerant capacity
- Double wall vented protection between refrigerant and water
- Triple leak checked, shipped with N₂ holding charge

Part No. 4021577

Specifications subject to change without notice.

Certifications

- UL/cUL® (SA5939)
- ASHRAE 90
- CRN's available upon request

Sizing Guidelines

The Therma-Stor II-2 HF can accommodate refrigeration loads of up to 27 tons per circuit depending on refrigerant and evaporator temperatures. The individual circuits can be piped together in parallel to accommodate larger loads (see diagrams below). Single circuit units are available with larger refrigeration capacities (Therma-Stor II-1). Therma-Stor units are not intended as a substitute for air or water cooled condensers. These capacity ratings are based on approximately 15 lb. pressure drop at maximum capacity.

II-2 HF		
Max. Recommended Capacity (in tons) for Typical Refrigeration Systems		
Refrigerant	Low Temperatures	Medium Temperatures
R-22	25	27
R-134A	20	23
R-404A, R-502, R-507	18	20

Water Temperature Control

Incorporating provisions in the refrigerant piping to bypass hot gas around the Therma-Stor directly to the condenser is recommended for large capacity systems. This prevents water from overheating during periods of sustained refrigeration operation with no/low water demand. A typical arrangement incorporates a three-way valve operated by an aquastat that senses water temperature. An alternate arrangement is a water bleed valve that would bleed hot water out of the tank. An aquastat can be mounted on the mid-port if there is no recirculation loop or connected to the water outlet piping to sense water temperature. Refer to diagram A below.

Supermarket Applications

The Therma-Stor II-2 HF is often plumbed in series with a conventional water heater. See diagram B.

In applications with “batch” cleaning, adding a Therma-Stor TS-120 storage tank is recommended. The TS-120 can be installed to accommodate thermal-syphoning (circulating without a pump). See diagram C, refer to Therma-Stor 120 spec sheet for more information.

The Therma-Stor System is installed with a circulating loop, pump the water as slowly as possible and return to the 3/4” NPT mid-port. Do not circulate directly between the water heater and the Therma-Stor unit unless the heater has been deactivated so that it acts as storage only.

The individual circuits can be piped together in parallel to accommodate larger loads (see diagram D). Do not install both circuits of the II-2 HF in parallel on a single system that experiences low load conditions since this may trap liquid.

