



# Therma-Stor III-1

TS-209B  
Revised 6/13

## Heat Recovery Water Heater Specification Information



Therma-Stor plate design, with rapid, free-flowing paths for refrigerant gas, promotes excellent waste heat transfer throughout the tank.

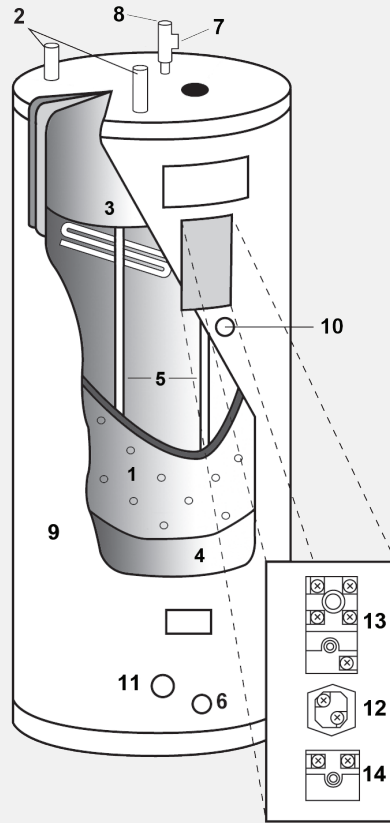
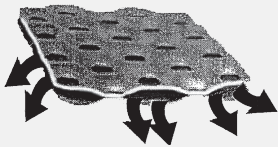

### Construction Specifications

1. Single circuit refrigerant heat exchange plate designed for maximum heat transfer with minimum pressure drop.
2. 1-5/8" O.D. refrigerant inlet and outlet.
3. Industrial glass lined 114-gallon hot water storage tank.
4. 2" foam-in-place urethane insulation.
5. Dual anode protection against corrosion for extended tank life.
6. 1-1/4" male NPT water inlet.
7. 1-1/4" male NPT water outlet.
8. 150 psi and 210°F pressure/temperature relief valve.
9. Attractive enameled galvanized external wrapper.
10. Mid tank 3/4" Male NPT connection for recirculating loop return (mid-port).
11. Stub-out for equalization tube (recommended for use when two or more Therma-Stors are piped in parallel; see diagram D).
12. 6000 watt medium density electric heating element. 208/230V single phase is standard, also available with 277V or 480V element.
13. Thermostat to control element (120°-180°F set point).
14. Thermostat to control 3-way reclaim valve or water bleed valve (110°-170°F Set point).

### Unit Specifications

- Tank Dimensions  
Diameter: 29 1/4", Height: 62 1/4"
- Unit with Fittings Dimensions  
Diameter: 31 1/2", Height: 67", Weight: 435 lbs
- 120 gallon nominal water capacity
- Rated for 450 psi refrigerant operating pressure
- Max heat exchange rating 80,000 BTU/HR
- 6000 watt back-up heating element
- 150 psi maximum operating water pressure
- R-16 insulation
- High refrigerant capacity
- Double wall vented protection between refrigerant and water
- Triple leak checked, shipped with N<sub>2</sub> holding charge

Part No. 4021540 – III-1 208/230V

Part No. 4021956 – III-1 480V

Part No. 4021955 - III-1 277V

*Specifications subject to change without notice.*

### Certifications

- UL (SA6294)
- ASHRAE 90

### Overview

The Therma-Stor III-1 Heat Recovery Water Heater features a single-circuit heat exchanger encompassing a 114-gallon water tank along with a 6 kW electric heating element and controls. The III-1 is compatible with refrigeration loads of up to 60 tons depending on refrigerant type and evaporator temperatures (refer to chart on the back). For larger refrigeration capacities and/or water use, multiple III-1 units can be piped together. Banks of two, three and four III-1's are common in facilities with higher hot water demand.

### Operation

Therma-Stor III-1 heats water by transferring refrigerant superheat to water. Hot gas from the compressor is piped through the III-1 en route to the condenser. The III-1 is compatible with any typical refrigeration system within sizing guidelines (using capillary tube systems with the Therma-Stor is normally not recommended). The 6000 watt back-up electric element provides additional water heating capacity. Plumbing recirculating loop return water to the mid-port allows recirc line losses to be heated with reclaimed heat without affecting overall heating efficiency. Hot water production depends on the evaporator load (capacity), run time of the compressor and water usage (see the Therma-Stor Return On Investment Calculation Form available at [www.HeatWaterForFree.com](http://www.HeatWaterForFree.com) for more information).

## Typical Applications

The Therma-Stor III-1 is ideally suited for facilities with high capacity refrigeration systems and substantial hot water demand. The III-1 is typically the only water heating system in a facility, replacing conventional gas or electric water heaters. Common installations include:

- Grocery stores
- Supermarkets
- Processing facilities

## Sizing Guidelines

The Therma-Stor III-1 can accommodate refrigeration loads of up to 60 tons depending on refrigerant and evaporator temperatures. Units can be piped together in parallel to accommodate larger loads (see diagrams below). If multiple tanks can not be used, larger loads can be accommodated by incorporating a bypass valve (see Diagram D below). Therma-Stor units are not intended as a substitute for air or water cooled condensers. These capacity ratings are based on approximately 15 lb. pressure drop at maximum capacity.

<b>III-1</b> Max. Recommended Capacity (in tons) for Typical Refrigeration Systems		
Refrigerant	Low Temperatures	Medium Temperatures
R-22	60	64
R-134A	47	53
R-404A, R-502, R-507	42	51

## Water Temperature Control

Incorporating provisions in the refrigerant piping to bypass hot gas around the Therma-Stor directly to the condenser is recommended for large capacity systems. This prevents water from overheating during periods of sustained refrigeration operation with no/low water demand. A typical arrangement incorporates a three-way valve operated by an aquastat that senses water temperature. An alternate arrangement is a water bleed valve that would bleed hot water out of the tank. The III-1 features a built-in aquastat designed to operate a three-way or water bleed valve. Refer to diagram A below.

## Supermarket Applications

The entire refrigerant load (up to 64 tons) of the larger rack systems can be run through a single Therma-Stor III-1 Heat Recovery System.

In applications with "batch" cleaning, adding a Therma-Stor TS-120 storage tank is recommended. The TS-120 can be installed to accommodate thermal-syphoning (circulating without a pump). See diagram B, refer to Therma-Stor 120 spec sheet for more information.

If the Therma-Stor System is installed with a circulating loop, pump the water as slowly as possible and return to the 3/4" NPT mid-port. Do not circulate directly between the water heater and the Therma-Stor unit unless the heater has been deactivated so that it acts as storage only.

Therma-Stor units can also be installed in parallel to accommodate larger loads. Connecting the equalization tubes assures pressure equalization so that refrigerant flows evenly through each tank at all times. See diagram C.

